

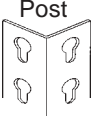

# WORKBENCH

## ASSEMBLY INSTRUCTIONS

SAMPLE MODEL NUMBER CODE	
Series 200B _____	<b>BW4-9636-WH</b>
Workbench _____	
Number of Shelves _____	
Shelf Width in Inches _____	
Shelf Depth in Inches _____	
Particle Board Decking Included _____	
Shelf Deck Support (1 per shelf) _____	

COMPONENT DESCRIPTIONS	
 <p>Post</p>	 <p>Shelf Deck Support</p>
 <p>Double Rivet Beam</p> <p>Flange Up →</p>	 <p>3" Shelf Clip</p>

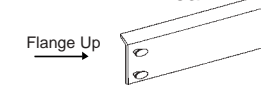
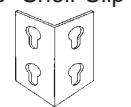
### STEP 1A: Bottom Shelf

- Components: 4 Posts (P)  
1 Double Rivet Beam (DR)  
These are the steel beams that support the front and back of the shelf  
2 Double Rivet Beams (DR)  
These are the steel beams that support the sides of the shelf
- Build the bottom frame by inserting the Double Rivet Beam (flange up, see drawing top right) into the bottom #5 & #6 keyholes of each post. Firmly hit beams into the post using a rubber mallet. See Figure 1A.

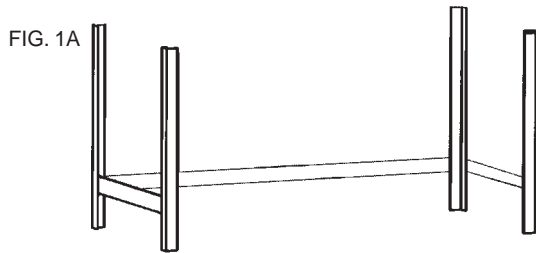

### STEP 1B: Bottom Worksurface

- Components: 1 Double Rivet Beams (DR)  
This is the steel beam which supports the front of the shelf.  
1 Shelf Deck Support(SDS)  
These are the steel beams that support the center of the decking. (if applicable).
- If your workbench includes a bottom workksurface insert the Double Rivet Beam across the front of the unit. Hit beam firmly into the post. Bolt 1 Shelf Deck Support from front to back in the center of shelf (if applicable). See Figure 1B.

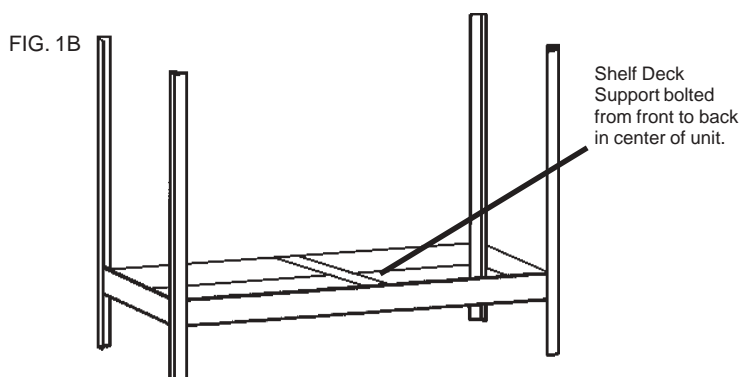

### STEP 2: Top Worksurface

- Components: 2 Double Rivet Beams (DR)  
These are the steel beams that support the front and back of the shelf  
2 Double Rivet Beams (DR)  
These are the steel beams that support the sides of the shelf  
1 Shelf Deck Support (SDS)  
These are the steel supports that support the center of the decking (if applicable)
- Build the Top Worksurface by inserting the Double Rivet Beams (flange up) into the top two keyholes of each post. If your workbench includes an elevated shelf be sure to insert the back support beam level with the front support beam. Bolt 1 Shelf Deck Support from front to back in the center of the shelf (if applicable). See figure 2A or 2B.

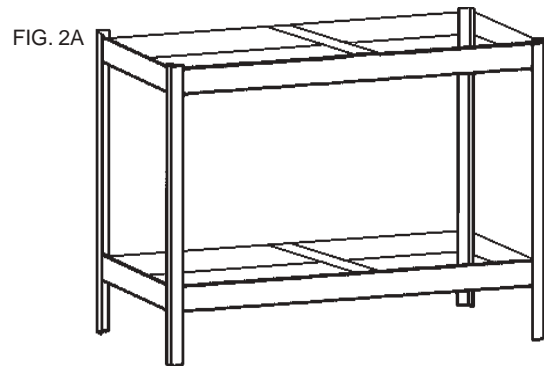

OR

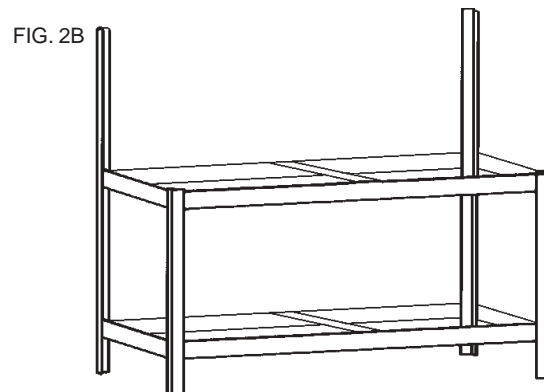

Continued on reverse side.

# WORKBENCH ASSEMBLY INSTRUCTIONS

## STEP 3: Elevated Shelf

1. Components: 2 Double Rivet Beams (DR)  
These are the steel beams that support the front and back of the shelf  
2 Double Rivet Beams (DR)  
These are the steel beams that support the sides of the shelf  
2 Shelf Clips  
These are the 3" post clips which help support the elevated shelf
2. Insert the back support into the top two keyholes of the back posts. Firmly hit beam into posts. Insert the side supports into the top two keyholes and firmly hit beams into posts.
3. To insert the front support beam use a 3" Clip Post. The Clip Post will hold the corner of both the side support and front support. Carefully hit the beams securely into the clip. Repeat for opposite side of the elevated shelf. See Figure 3.

FIG. 3

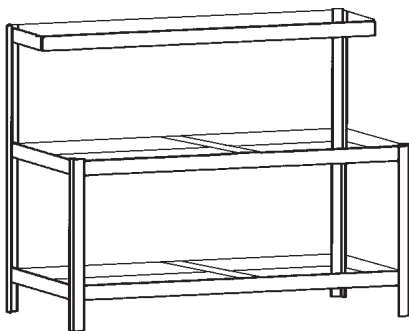

## STEP 4: Particle Board Decking

1. Place one particle board decking on each shelf.  
(Picture shown below is a completed unit of Worksurface plus top and bottom shelves.)

FIG. 4

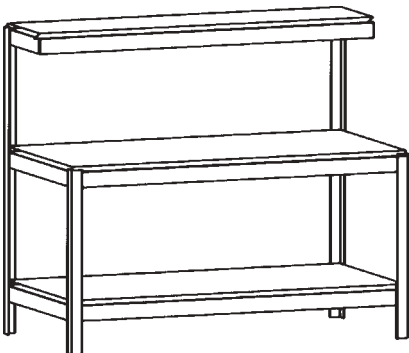

### SPECIAL NOTES:

1. It is recommended that a rubber mallet be used to hammer the beams securely into place.
2. Cardboard or carpet can be used to protect flooring.

## Workbench Units when complete:

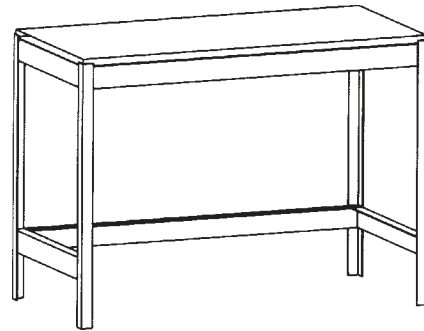

Worksurface Only.

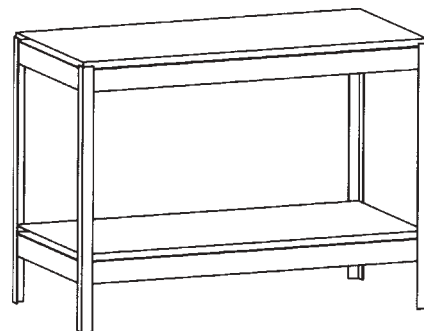

Worksurface plus bottom shelf.

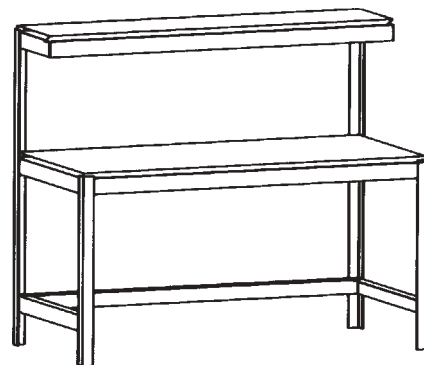

Worksurface plus top shelf.

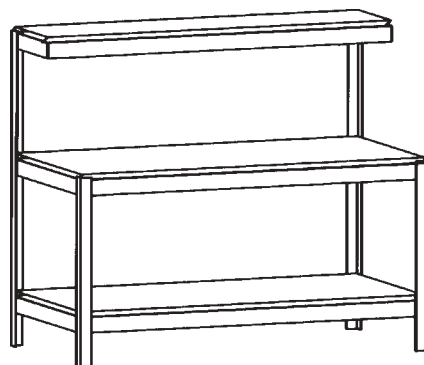

Worksurface plus top and bottom shelf.